

MATTHEWS BROS. & Co.,

MANUFACTURERS



AND DEALERS IN

FURNITURE,

FINE PIER &



Mantel Glasses,

413, 415 and 417 Broadway, MILWAUKEE.

Figure 1: Advertisement for "Matthews Brothers and Company Furniture" from 'An Illustrated Description of Milwaukee.' The Milwaukee Sentinel, 1890, p.145. In the collection of the Milwaukee Historical Society.

Treatment of Objects from the Darwin Martin House

Pamela Kirschner

ABSTRACT: This paper includes the results of a continuation of a study¹ conducted in 1997 to investigate the upholstery, construction and finishes of several pieces of furniture from the Frank Lloyd Wright designed Darwin Martin House in Buffalo, New York. This paper goes further into depth about physical evidence and historical practices. It provides technical and historical information that will assist conservators and curators in understanding the materials and construction of Frank Lloyd Wright furniture from the early twentieth century. The information in this paper will also assist in the proper care and conservation treatment of these objects. Methods of analysis used include X-radiography to determine construction techniques, ultraviolet light and microscopy to aid in determining the finishes as well as polarized light microscopy for fiber identification. Historical references, original photographs and drawings were utilized to confirm information found in analysis.

Introduction

OVER SIXTY PIECES OF FURNITURE FOR the Darwin Martin House designed by Frank Lloyd Wright, as well as some Stickley pieces approved by Wright for the house, were brought to Peebles Island Resource Center near Albany, New York to receive conservation treatment. The furniture suffered some abuse over the years, but has held up well with only some loose veneer, small losses, grime, some refinishing and replacement upholstery. The Frank Lloyd Wright furniture from the Darwin Martin House has the visual appearance of furniture made in the style of the American Arts and Crafts Movement. For example, both use solid and veneered quarter-sawn white oak with a tinted clear finish to give the look of aged oak. Many interiors of the other Frank Lloyd Wright Prairie style houses have been refinished as well as the furniture. The Darwin Martin pieces are unique compared with most early Frank Lloyd Wright furniture in that they all retain areas of original finish. No original show covers remain on the furniture, but there is physical evidence still present. It is imperative to understand the finishes and materials used to treat and preserve the furniture properly.

Background on Matthews Brothers Company

The Matthews Brothers Manufacturing Company of Milwaukee, Wisconsin was responsible for almost all of the interior trim and cabinet work as

well as the furniture in the Darwin Martin House. This includes construction and finishing. An 1890 advertisement for the Matthew Brothers Company, describes the manufacturing of high end furniture and offers refinishing and upholstery services. The company started in 1857 as a small store selling furniture. They had two factory buildings by 1879, one for the offices and upholstery work and another fully equipped with the latest and best machinery for building furniture² (*fig. 1*).

Materials and Techniques Background Finish

The fuming process of oak has been mentioned many times in references to finishes of the period. No evidence, however, was found that the Frank Lloyd Wright furniture was fumed. Casual experiments with fuming white oak were conducted using a small piece of oak in a container with a dish of ammonia (*fig. 2*). Within a few hours, the oak began to turn a dark gray (*fig. 3*). This is not consistent with the color of Frank Lloyd Wright furniture from the Darwin Martin House which is a warmer red color. Also, fuming the oak not only colored the softer areas of the oak, but as mentioned in the Stickley³ recipes, also the dense rays. Most of the rays on the furniture from the Martin house are very pronounced and light in color. Also from descriptions on fuming oak, the outcome is not even and often has to be touched

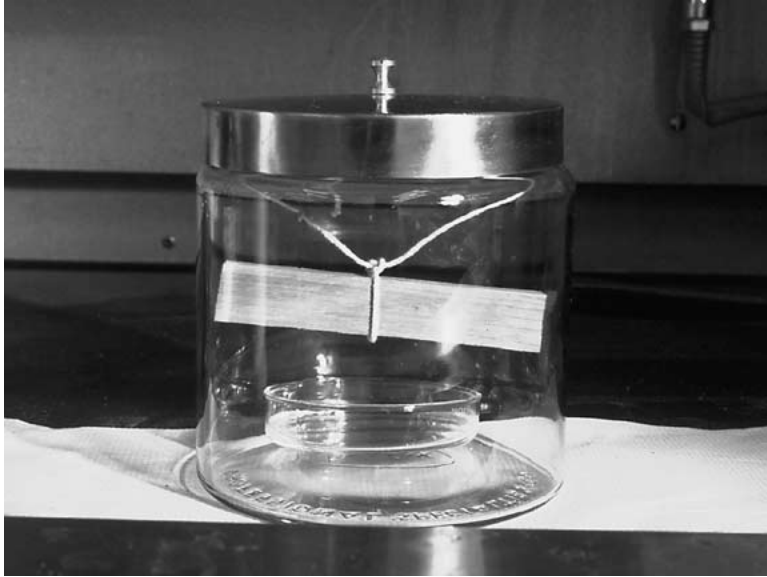

Figure 2: A piece of white oak placed in a jar with a dish of aqueous ammonia.

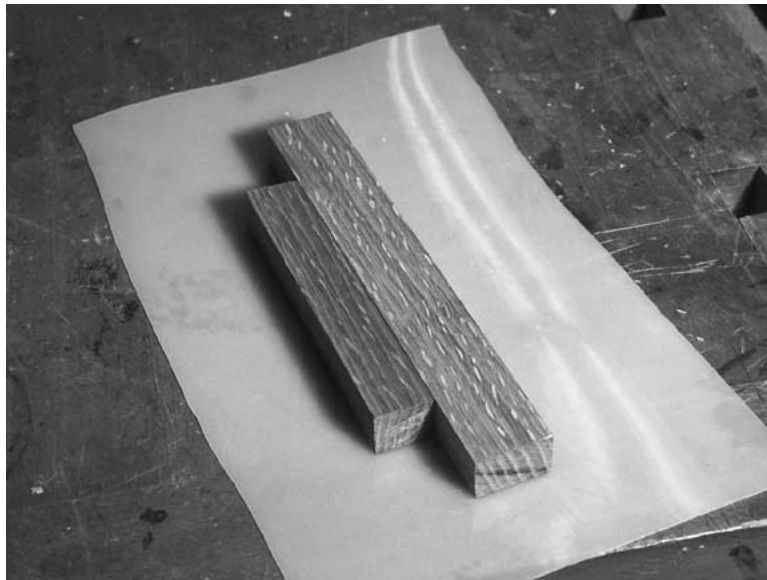

Figure 3: When the piece of oak was removed, it had turned dark gray. A piece of unfumed white oak from the same board is placed next to the fumed piece.

up. It may not have been economical for a furniture factory such as the Matthews Brothers to fume the furniture. The process requires an extra step and presents dangerous health issues. The period finishing techniques appear to have created the desired effect without the fuming process.

Darwin Martin kept a detailed journal from 1905 which included directions for touching up patch-

es of missing finish and are labeled “Oak-Fumed” and “Mahogany.”⁴ He requested in a letter to the Matthews Brothers Company a supply of stains to touch up molding that was not completely covered.

These are possibly the directions for application of the stains he requested:

Oak-Fumed, Directions for touching up patches. Apply one coat stain, when dry sandpaper and then apply one coat-shellac. Should the patches be too light, put a little Van Dyke Brown and a little Lamp Black into the shellac, and patches can be toned down that way. After the places are all touched up then apply one coat of flat varnish over them.

Mahogany, Directions for finish-ing. Apply one coat 1st-coat stain, when dry sandpaper, then oil the stained parts over with the oil stain. Next day stain over parts with the 2nd-coat stain, when dry apply three coats with shellac, then rub with pumice stain and oil.

There appears to be some evidence of filler material used to darken the pores in the oak of the Darwin Martin furniture, although they are not completely filled. Fill material was likely mixed with pigments and a binder to hold the color in the pores. Wood filler often contains glue or size as a binder mixed with pigments of the desired color. French chalk was a popular fill material with oak. The filler would have been applied and wiped off.

The recipe for the “fumed oak” in Martin’s journal mentions the application of a flat varnish, which would include a mixture of oil, such as linseed oil, and a natural resin, such as mastic or copal. Oil and turpentine mixed will act faster than oil alone and will accept a color tone added in powder form. Beeswax has been traditionally added along with

vinegar, denatured alcohol, paraffin oil and butter of antimony.⁵

Also in Darwin Martin journals were recipes for furniture polish:

12/13/03 [Furniture Polish]

oil of Marbane(?) 1/2 lb
caustic soda 1 stick
vinegar 1 qt
wood alcohol 1 pt
turpentine 10 gal
benzine or naphtha 10 gal
ammonia 1 pt
hot water 3 gal
cup grease 15 lbs
(can substitute olive oil for grease for a better polish)
Mix together first oil of Marbane, Turpentine, Benzine or Naphtha, Ammonia, Hot water, cup grease

Another recipe was found in a later journal:

6/19/09
1 pt. Linseed oil boiled
2 oz. Black rosin
2" spirits nitre
4" Distilled vinegar
1" butter antimony
wash surface alternately with boiling water and vinegar and polish

Structure

The use of lumber core and cross veneers is prevalent in the furniture. Methods of using composite wood were incorporated into furniture manufacture in the nineteenth century and possibly earlier. Furniture makers Michael Thonet and Henry Belter used lamination in the 1830s and 1840s. Uses for these new methods continued into the second half of the nineteenth century, and these methods were used often for backs of chests, mirrors, chair backs and seats. Lumber core is a type of plywood, which incorporates boards as its core rather than thin veneers. The boards are placed next to each other with alternating grain to avoid warping. One or two layers of veneer is placed on either side. Lumber core had more extensive earlier use than plywood in elements such as desktops, which require large, stable panels. Only two adhesives were available in

the nineteenth century for this application. These were animal protein glue, derived from collagen, and casein glue, derived from milk protein.⁶

Upholstery Background

In a letter dated 1905 from O. Lang, the contractor for the Darwin Martin House, to the Matthews Brothers, there is reference that all of the upholstery would be done in Buffalo.⁷ Letters from 1906 between Darwin Martin and Wright describe an upholsterer's shop called Faust-Mitchell at 827 Main Street in Buffalo. The furniture was shipped to the shop from Milwaukee and was held there for some time while Wright chose the appropriate colors. An interview with Martin's daughter, Dorothy Martin Foster, in November 1971 includes the listing of original colors being chosen by Mrs. Martin and Wright. The colors described for the house interiors were yellow, gold, green, orange, and brown as well as gold leaf.⁸ Darwin Martin's journal from 1903 describes the colors for the paint on the south room ceiling, which included yellow lake (8 parts) and chrome green (1 part).

There are no records found of invoices or lists of actual fabrics. However, there are invoices dating 1878–1895 from the Matthews Brothers Company that include mohair, leather and plush materials.⁹ Invoices for fabrics used in several other Wright houses built shortly after the Martin House include mohair fabrics. These records are part of the Niedekin files at the Prairie School Archives in Milwaukee, Wisconsin. Niedekin was an interior designer who collaborated with Wright on the Coonley, Meyer May, Robie and Irving Houses.¹⁰

Period Furniture and Fabric History

By the early 1870s the seven-piece parlor suite had become a staple of furniture manufacture. Almost all such suites included a tete (sofa), an upholstered armchair, an upholstered armless lady's chair, and four small chairs having "brace" or "stuffed" backs and an upholstered seat. Ownership of a parlor suite would create a modern parlor. The 1883 catalogue of Jordan and Moriarty, a New York City furniture store, offered "an extensive stock of parlour suites in Hair cloth, Repps, Brocatelle, Satin, Satin De Laine, Damask, Raw silk, etc." Of the two large chairs in a suite, the armchair was sometimes openly termed a "gentleman's chair" with an upholstered seat and back and upholstered

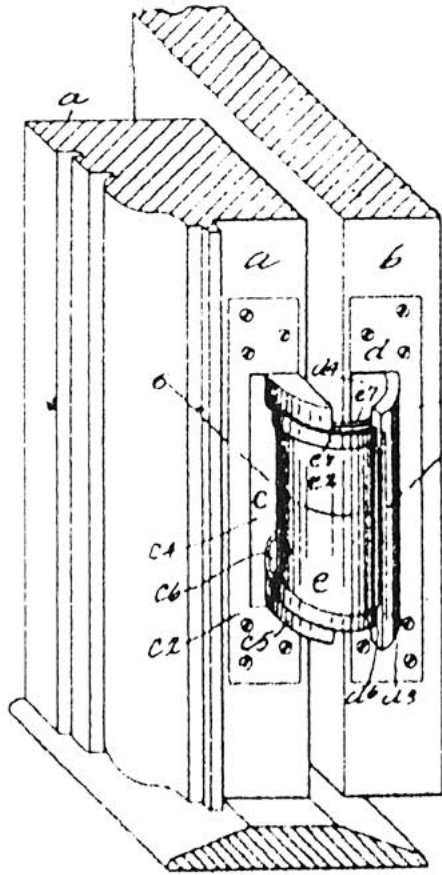

Figure 4: Illustration of the Soss Hinge from the 1903 Patent Records. (Illustration provided by David Bayne, Furniture Conservator, Peebles Island Resource Center)

arm rests.¹¹ An updated variation of this practice can be seen in the Darwin Martin House collection which includes different forms of sofas and chairs. There are several armchairs from the house that were based on the style of the gentleman's chair.

As mentioned above, satin was a popular material during the late nineteenth-century. Satin refers to cloth with warp-faced floats and sateen to a weft-faced version. Satin can be made from a silk warp with a cotton or linen weft and is more ordinary than Satin de Lyon, which is pure silk. Satin de Laine is satin made up of wool.¹²

Pile fabrics were also popular. Pile weaves are made with an extra set of warp or weft yarns (that are either cut or left uncut) to hide the underlying ground warp and weft. In 1883, the Hartford Silk Manufacturing Company showed "black silk plush" and announced that soon it would have "full lines

of the same in red, blue, old-gold, olive and other popular shadings." The warp pile could be used to create pattern in several ways, such as cut and uncut loops or "pile-on-pile" velvet, which is cut or uncut pile woven at two or more heights. In voided velvet the pattern was woven in pile on a flat weave ground. Utrecht Velvet, Mohair Plush, or Furniture Plush were all names given to a velvet whose warp pile was "mohair," a yarn made from the fleece of goats. An 1881 publication noted, "The best Mohairs are almost indestructible. Mohair is elastic and has lustre." In a publication from 1881 a description for mohair states, "On account of its stiffness, it is rarely woven alone; that is, when used for filling, the warp is usually of cotton, silk or wool." In an 1892 publication, mohair furniture plush was described as being used chiefly for cars and office furniture. It had a mohair pile woven into a linen foundation and was manufactured in America.¹³ A Sears catalog from 1902 advertised fabrics including crushed plush, three-tone velour and satin fabric.¹⁴

Glass and Hardware

Each piece of furniture either has casters, which are made of a ball in a cup, or round-plated metal glides. Of particular interest in the pieces examined to this date are the glass panels and invisible hinges found on two plant stands (03FLW00015 & 16). These stands have four identical framed glass panels on all sides with one of them being a door allowing access to inside the cabinet. The door has only a small round brass handle visible.

Hinges found on the plant stands are similar to ones found on cabinets from the house. The hinges on the cabinets have a patent date (Dec 8, 1903) on them and were found to be made by Joseph Soss from New York, New York¹⁵ (fig. 4). Joseph Soss was the inventor of the auto hinge. The hinges are made up of three parts cast with some hand work. One part is attached to the door, and another is attached to the object itself. The third part is a thin half-cylinder piece that slides back and forth between the two parts as the door is opened and closed. The main body of the hinge is barrel shaped.

The glass in the panels of the plant stands is 1/4 inch thick, clear with a slight green tint and some trapped air bubbles. The air bubbles indicate that the glass was blown and then polished flat. A 1911 source, *Decorative Glass Processes*, by

Arthur Louis Duthie describes period methods of creating plate glass. "Sheet" glass was made by blowing in cylinders 5 feet or more in length. These were split open and flattened out in a kiln. There were first, second, third and fourth qualities according to the air bubbles, defects or waves present. "Patent plate" is sheet glass that has been ground and polished on both sides to remove the wavy surface. A polishing machine was used that allowed the sheet of glass to be very flat and transparent. A jointed arm carried a rubber block with a ball joint allowing contact with the surface of the glass. The block was faced with a mixture of rouge and water. The block was moved over the surface in a rotary motion and the pressure could be regulated by hand.¹⁶

Scientific Analysis

Procedures (Materials and Methods)

Sampling

Fiber samples were removed from several upholstered pieces in the collection. They include two upholstered arm chairs (03FLW00001 and 03FLW00003), a sofa with cabinets (03FLW00024) and two tall back or "Pillar Back" chairs (03FLW00037.1 and 03FLW00037.2). Fiber samples were removed from fabric samples believed to be original on the upholstered armchairs, sofa with cabinets and Pillar back chairs. Threads and individual fibers were found under nails, inside nail holes or caught in cut lines.

Finish samples were taken of the finish on the sofa with cabinets (03FLW00024) that was darkened from polishing. The typical areas of original finishes found on the furniture from the Darwin Martin House are clear finishes above quarter sawn oak veneer or solid oak. The study done in 1997 included FTIR analysis, which found the original finish to contain a mixture of oil, natural resin, possibly a cellulosic binder and inorganic materials (likely pigments and filler materials).

Measurement and Data

The techniques used for analysis included X-Radiography, hand-held ultraviolet light and microscopy. All analysis was performed at Peebles Island Resource Center in Waterford, New York. (see the previous study mentioned that includes FTIR analysis).

The X-Radiography analysis was used to understand the construction techniques of one of the dining room chairs. A chair was placed onto an X-ray machine by CGR Medical Corporation modified for flat objects. The X-ray was taken at 60 KV and 50 MA for four minutes.

Microscopy was performed with white light as well as ultraviolet light under 100x and 200x using an Olympus Vanox microscope. The samples were mounted in polyester resin, allowed to dry under a tungsten bulb for four hours and then sanded and polished using Micromesh.

The fiber analysis was performed on an Olympus Vanox microscope using both 200x and 400x magnification in transmitted light. Fibers were removed from the fabric samples and placed onto microscope slides with cover slips. Two drops of clear fingernail polish were applied at the edges of the cover slip to adhere it to the slide. The fibers were examined with normal light and cross polarization.¹⁷

Analysis and Evaluation

Personnel and Facilities

The project was supervised by David Bayne, Furniture Conservator at Peebles Island. Deborah Trupin, Textile Conservator at Peebles Island Resource Center, assisted with the fiber analysis and Joyce Zucker, Paintings Conservator at Peebles Island Resource Center, assisted with microscopy.

Results and Discussion

X-Radiography

X-rays were taken of one of the dining room chairs in the collection (03FLW00036.2 back and the slip seat). The back shows dowels attaching the stiles and the crest rails as well as two dowels at the top of each spindle. This is consistent with construction found in other pieces of the Darwin Martin House furniture. The study done in 1997 included X-rays of the sofa (03FLW00009). These revealed dowels, lumber core and veneer.

Cross Sections

Cross sections of areas of finish believed to be original on the inside of the cabinets of sofa 03FLW00024 show a creamy-white fluorescing finish with a thin layer of dark particles on top.

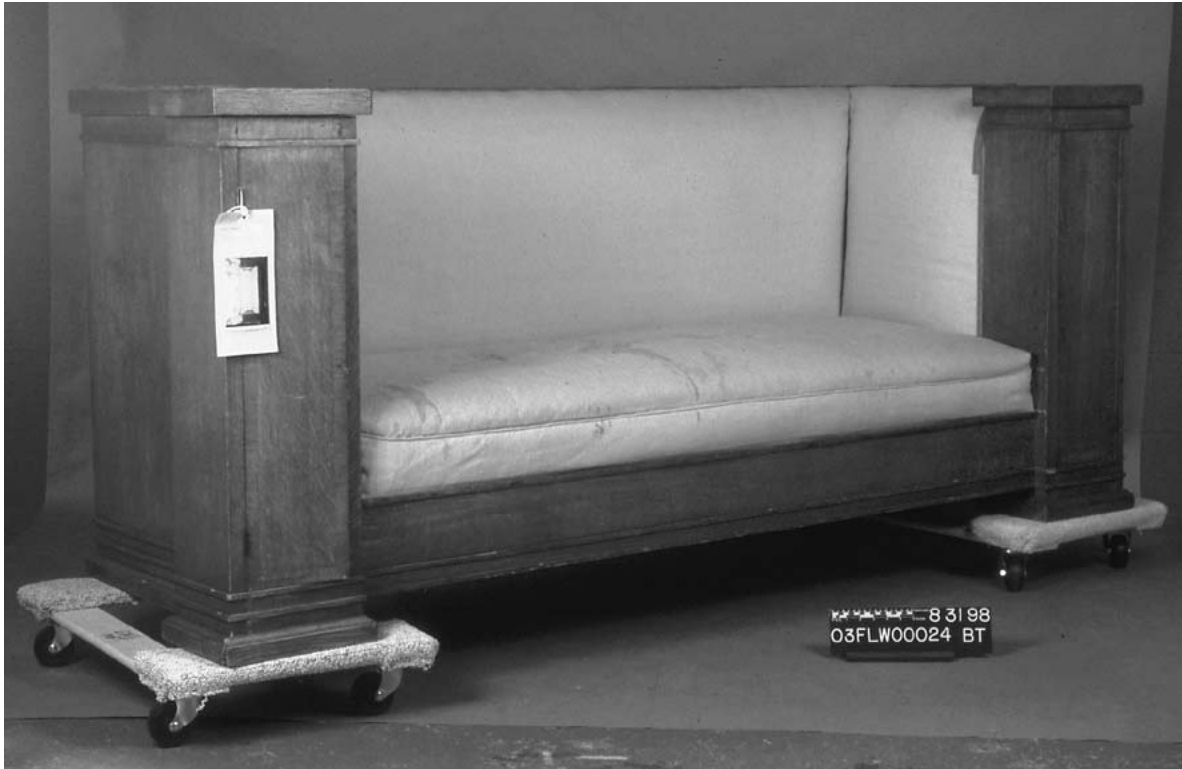

Figure 5: A before treatment shot of the Library sofa (03FLW00024) from the Darwin Martin House.

The thin layer of dark particles is likely soot trapped in wax. Samples from the sides of the sofa, which are darkened from polishing and environment, show a creamy-white fluorescing layer underneath and a dark brown layer with large particles in it. The finish is highly disrupted.

The use of a 2% solution of Rhodamine B stain (.25% in ethanol) in equal parts of ethanol and xylene was used to determine the presence of oils. After viewing with a cover slip and a drop of Shellsol (petroleum distillate), a drop of stain was applied, wiped off immediately and cleared with another drop of Shellsol. During the staining procedure, the dye is delivered in a carrier solvent and the dye diffuses from the solution into the substrate. Characterization of finish layers using stains requires considerable knowledge and experience. However, the use of this stain for the presence of lipids proved very helpful for distinguishing areas of original finish and areas of synthetic finishes. The finishes proved positive for oils by fluorescing bright orange where they are believed to be original and did not react positively to the synthetic finishes.

Fiber Analysis

Of the objects examined to date, all were found to have replacement upholstery. The current show covers did not show very much wear and did not match the show covers seen in original photographs. The covers were removed and any physical evidence of fabric was examined.

Upholstered armchair (03FLW00003)

After removing the current green synthetic show cover, a large area of original show cover material was found on the back of the chair as well as original under-upholstery on the seat back and arms stuffed with moss and horse and hog hair. The material present is a plush-on-plush fabric with rust colored mohair warp and yellow and beige cotton weft. It matches a swatch kept at the University at Buffalo Archives that is believed to be original to the house.

Upholstered armchair (0FLW00001)

The blue-green cover with a diamond pattern was removed and small pieces of what is believed to be original material remains under nails as well as original under upholstery on the seat back and arms.

The pieces of material are also a plush with a yellow mohair warp and blue cotton and linen weft.

Sofa with cabinets (03FLW00024) (fig. 5)

The yellow wool cover was removed and evidence was found of two show cover campaigns underneath as well as original under-upholstery. Below the current yellow wool was another yellow wool woven in a twill. Nail holes were found underneath this confirming an earlier cover. The original photograph shows a dark colored fabric with a satin sheen. Further searching for original evidence revealed pieces of material in the cut line of the seat cushion frame. These fibers were analyzed and were found to be blue and green mohair and cotton fibers (fig. 6).

Pillar back chairs (03FLW00037.1 and 37.2)

The green synthetic material was removed as well as the under-upholstery, which was found to be a replacement. Individual wool and cotton fibers were found in the cut lines. Evidence was found of three show cover campaigns. Individual red mohair and cotton fibers were found as well as yellow wool pieces of material in the cut lines and also under one nail and the current green cover. A 1972 photograph shows what appears to be a dark colored plush material that may be the original material.

Conclusions from Scientific Analysis in Comparison to Historical Information

The original finish was found to contain a mixture of oil, natural resin, possibly a cellulosic binder and inorganic materials (likely pigments and filler materials). These materials match the recipe in Darwin Martin's journal for "fumed oak." This includes the application of a stain with pigments that fill the pores, a coat of shellac and a layer of varnish (oil and resin) above that.

Revealing the construction of the furniture through X-radiography allows us to place the objects in context with the time period and techniques used in American factory-made Arts and Crafts furniture. This includes the use of lumber core, veneer and dowels.

The fiber analysis has given us varying degrees of insight into the original show cover materials. The two upholstered chairs were found to have

mohair plush fabrics with diamond patterns, one rust colored with a cream or yellow background, the other yellow mohair with a blue cotton and linen background. The sofa had a woven mohair and cotton fabric with a satin finish and is believed to have been green. The Pillar back chairs may have had a mohair pile originally in a solid red color. Mohair plush was found in historic references to be a common material used in the period.

Treatment

The treatment of these objects includes structural repair, finish work and upholstery. Treatments performed are as minimally intrusive as possible. The overall goal is to allow the piece to appear aged but well cared for. Areas of wear that can not be easily repaired or removed were left. Areas of original finish were cleaned gently with slightly dampened cotton and water, and xylene and acetone were used to remove darkened areas of cross-linked oil polish or areas of in-painting



Figure 6: A fabric sample found along the cut lines around the sofa cushion rail containing blue and green mohair and cotton fibers.



Figure 7: A cleaned area of the sofa finish that had darkened due to polishing and environment.

from previous replacements. The back of the sofa with cabinets (OFLW00024) required the use of a reformer or amalgamator using di-acetone alcohol as well as ethyl alcohol brushed onto the surface.¹⁸ Shortly after the reformer was applied, xylene mixed with a small amount of benzyl alcohol was used to remove hardened oil polish that had darkened. Rather than remove all the darkened polish and risk removal of original finish, some darkened polish was left in place (*fig. 7*). Finish samples were taken and analyzed to ensure that original finish still remained on the surface. The final appearance of the finish is aged. Soluvar was applied to re-saturate the finish as well as dry pigments to color any uneven areas. A thin layer of shellac was applied, and then Blue Label carnauba and beeswax was rubbed onto the surface. Any detached molding was re-adhered, and new white oak molding was shaped, applied and in-painted to match the surrounding area. Hot animal hide glue was used as a reversible adhesive throughout the treatments. Also, animal hide glue was used as a reversible boundary layer for applying fills and Araldite epoxy (Ciba-Geigy) was used as a gap filler. New oak repairs were finished using gilder's whiting with Behlen's fresco pigments as a filler, Soluvar varnish (Liquitex) with Behlen's pigments

as a stain as well as for saturation, and shellac or simply Blue Label carnauba and beeswax. Some fills were matched with the surrounding area using acrylic paints. Any original under-upholstery will be stabilized and covered in linen to create a profile like the original. Appropriate show cover materials will be chosen based on historical and physical evidence, and they will be applied using non-intrusive upholstery methods. Sewing strips of Nomex were covered with linen using glue on one side and tacked to the tacking edge spaced as far apart as possible for sewing the under cover and show cover in place.

Conclusions

The information included in this paper provides historical as well as physical information about the furniture from the Darwin Martin House. The historic information of methods and materials in the period is consistent with physical evidence found on the furniture. Although the furniture is unique in design, it is similar to the furniture produced as a result of the Arts and Crafts Movement. Also, the methods of construction are typical of the period—dowels, mitered corners and lumber core that allowed for the stabilization of large boards for sofa backs or table tops. The hardware and uphol-

stery fabrics were those available at the time. This information will enable the proper treatment and care of the objects and assists with the preservation of original materials. The final conservation treatment methods chosen are based on the physical and historical information found. The Darwin Martin House is an excellent resource to aid in understanding the original appearance of Frank Lloyd Wright furniture from this period.

Acknowledgments

The author would like to thank the following for their help and support:

David Bayne, Furniture Conservator, Peebles Island Resource Center

Jan Carlson, Senior Scientist, Winterthur Museum

Chris Densmore and Rodney Obien, State University at Buffalo Archives

Jack Quinan, Curator for the Darwin Martin House

Deborah Trupin, Textile Conservator, Peebles Island Resource Center

Joyce Zucker, Painting Conservator, Peebles Island Resource Center

Notes and References

1. Kirschner, Pamela. "Frank Lloyd Wright: a Case Study of Objects from the Darwin Martin House." Wooden Artifacts Group Postprints, June 1998. Arlington, Virginia, American Institute of Conservation of Historic and Artistic Works Annual Conference.
2. Advertisement from "An Illustrated Description of Milwaukee." *The Milwaukee Sentinel*, 1890. p. 145.
3. Gustav Stickley's *Craftsman Catalog*, 1904.
4. Darwin Martin "Journal from 1905." State University of New York at Buffalo Archives.
5. Oughton, Frederick. *The Complete Manual of Wood Finishing*. New York, Stein and Day, 1982. pp. 125-129.
6. Klim, Susan. "Composite Wood Material in Twentieth Century Furniture." *Postprints of Wooden Artifacts Group*, AIC meeting in Richmond, VA 1990. p. 2.

7. Correspondence between Darwin Martin, Frank Lloyd Wright, Matthews Brothers and O. Lang. State University at Buffalo Archives.

8. Interview with Dorothy Martin Foster by Sue Greenwood, November 1971. University Archives, University at Buffalo. Tr 104.

9. Invoices from the Matthews Brothers Company in the collection of the Milwaukee Historical Society.

10. Robertson, Cheryl. *Frank Lloyd Wright and George Mann Niedekin: Prairie School Collaborators*. Milwaukee Art Museum and Museum of Our National Heritage, 1999.

11. Grier, Katherine C. *Culture and Comfort: People Parlors and Upholstery, 1850-1930*. Massachusetts, University of Massachusetts Press, 1988. pp. 205-209.

12. Adrosko, Rita. "Identifying Late 19th-Century Upholstery Fabrics," Preprints of a Symposium held at Colonial Williamsburg. Colonial Williamsburg, 1990. p.107.

13. *ibid*, pp. 114-116.

14. Amory, Cleveland. Sears, Roebuck and Co. "Catalogue III, 1902 edition," New York, Bounty Books, 1969, p. 777.

15. U.S. Patent December 8, 1903.

16. Duthie, Arthur Louis. *Decorative Glass Processes, Cutting, Etching, Staining and Other Traditional Techniques*. New York, Dover Publications, Inc., 1982. p. 16.

17. McCrone, Walter C., Delley, John Gustav. "The Particle Atlas, edition two, volume II," *The Light Microscopy Atlas*. Michigan, Ann Arbor Science Publishers, Inc., 1973. pp. 348-352.

18. Feller, Robert L. *On Picture Varnishes and Their Solvents*. Washington, National Gallery of Art, 1985. pp. 178-181.